

UT-Series
UT-800, UT-1200, UT Spectrum

TK 60652-OP (Rev. 3, 04-18)

Copyright© 2018 Thermo King EMEA
Printed in Ireland

Disclaimer

This manual is published for informational purposes only. Thermo King Corporation makes no representations or warranties, express or implied, with respect to the information, recommendations and descriptions contained in this manual and such information, recommendations and descriptions should not be regarded as all-inclusive or covering all contingencies. In the event you have any questions or require further information, please contact your local Thermo King dealer.

The procedures described herein should only be undertaken by suitably qualified personnel. Failure to implement these procedures correctly may cause damage to the Thermo King unit or other property or personal injury.

The manufacturer, Thermo King Corporation, assumes no responsibility for any act or action taken on the part of the owner or operator in the repair or operation of the products covered by this manual that are contrary to the manufacturer's printed instructions. No warranties expressed or implied, including warranties arising from cause of dealing or usage or trade, are made regarding the information, recommendations, and description contained herein. The manufacturer is not responsible and will not be held liable in contract or in tort (including negligence) for any special, indirect or consequential damages, including injury or damage caused to vehicles, contents or persons, by reason of the installation of any Thermo King product, its mechanical failure or the failure of owner/operator to heed caution and safety decals strategically located on the product.

Software Licence

The product includes software that is licensed under a non-exclusive, non-sub-licensable, terminable and limited license to use the software as installed on the product for its intended purpose. Any removal, reproduction, reverse engineering, or other unauthorized use of the software is strictly prohibited. Hacking the product or installing unapproved software may void the warranty. The owner or operator shall not reverse engineer, decompile, or disassemble the software, except and only to the extent that such activity is expressly permitted by applicable law notwithstanding this limitation. The product may include third party software separately licensed as specified in any documentation accompanying the product or in an about screen on a mobile application or website that interfaces with the product.

Table of Contents

Introduction	3	Premium	15
Safety Precautions	6	CYCLE-SENTRY™ Start-Stop Controls	16
General Safety Practices	6	Defrost	16
Automatic Start/Stop Operation	6	DAS - Data Acquisition System	16
Battery Installation and Cable Routing	7	Electric Standby	17
Refrigerant	8	Engine Compartment Components	18
Refrigerant Oil	8	Unit Protection Devices	18
First Aid	9	Manual Pretrip Inspection	22
Safety Decals and Locations	9	Operating Instructions	25
Refrigerant	11	Unit Operating Instructions Premium HMI Controller ..	25
Do Not Use Ether Starting Aids	12	Operating the TSR-3 Controller	28
Unit Description	13	Alarm Codes	29
General Information	13	Introduction	29
Diesel Engine	14	Loading and Enroute Inspections	30
ELC (Extended Life Coolant)	14	Pre-Loading Inspection	30
Clutch	14	Post-Loading Inspection	32
Thermo King Scroll Compressor	14		
HMI Control Panel	15		

Specifications37
Engine37
Fuses40
Electrical Control System42
Refrigeration System43

Warranty44

Maintenance Inspection Schedule45
Inspection and Service intervals45

Serial Number Locations47

Recover Refrigerant48

Introduction

There is nothing complicated about operating and maintaining your Thermo King unit, but a few minutes studying this manual will be time well spent.

Performing pre-trip checks and enroute inspections on a regular basis will minimize on-the-road operating problems. A regular maintenance program will also help to keep your unit in top operating condition. If factory recommended procedures are followed, you will find that you have purchased the most efficient and dependable temperature control system available.

All service requirements, major and minor, should be handled by a Thermo King Dealer for these very important reasons:

- They have factory trained and certified technicians
- They have genuine Thermo King replacement parts
- They are equipped with the factory recommended tools to perform all service functions
- The warranty on your new unit is valid only when the repair and replacement of component parts is performed by an authorized Thermo King Dealer.

IMPORTANT: This manual is published for informational purposes only and the information furnished herein should not be considered as all-inclusive or meant to cover all contingencies. If more information is required, consult your Thermo King Service Directory for the location and telephone number of the local dealer.

Customer Satisfaction Survey

Let your voice be heard!

Your feedback will help improve our manuals. The survey is accessible through any internet-connected device with a web browser.

Scan the Quick Response (QR) code or click or type the web address to complete the survey:

http://irco.az1.qualtrics.com/SE/?SID=SV_2octfSHoUJxsk6x



Emergency Assistance

Thermo Assistance is a multi-lingual communication tool designed to put you in direct contact with an authorized Thermo King dealer.

Thermo Assistance should only be contacted for breakdown and repair assistance.

To use this system, you need the following information before you call: (phone charges will apply)

- Contact Phone Number
- Type of TK Unit
- Thermostat Setting
- Present Load Temperature
- Probable Cause of Fault
- Warranty Details of the Unit
- Payment Details for the Repair

Leave your name and contact number and a Thermo Assistance Operator will call you back. At this point you can give details of the service required and the repair will be organized.

Please note that Thermo Assistance cannot guarantee payments and the service is designed for the exclusive use of refrigerated transporters with products manufactured by Thermo King Corporation.



BEA261

Belgium	+32 270 01 735
Denmark	+45 38 48 76 94
France	+33 171 23 05 03
Germany	+49 695 00 70 740
Italy	+39 02 69 63 32 13
Spain	+34 914 53 34 65
The Netherlands	+31 202 01 51 09
United Kingdom	+44 845 85 01 101
Kazakhstan	+7 7273458096
Russia	+7 4992718539
Others	+32 270 01 735

General Inquires and Unit Maintenance

For general inquiries please contact your local Thermo King dealer.

Go to www.europe.thermoking.com and select dealer locator for your local Thermo King dealer.

Or refer to the Thermo King Service Directory for contact information.

Safety Precautions

Thermo King recommends that servicing be done only by a Thermo King dealer. However, you should be aware of several safety practices. This chapter gives basic safety precautions for working with Thermo King units and describes the safety stickers on your unit that you should be familiar with.

General Safety Practices



WARNING: *Keep hands and loose clothing clear of fans and belts at all times when the unit is operating with the doors open.*



WARNING: *Exposed coil fins can cause painful lacerations. Service work on the evaporator or condenser coils should be done by a certified Thermo King technician.*



WARNING: *Do not apply heat to a closed cooling system. Before applying heat to a cooling system, drain it. Then flush it with water and drain the water. Antifreeze contains water and ethylene glycol. The ethylene glycol is flammable and can ignite if the antifreeze is heated enough to boil off the water.*

Automatic Start/Stop Operation

This unit is capable of automatic operation and could start at any time without warning.



WARNING: *The unit can start at any time without warning. Press the **OFF** key on the control panel and place the microprocessor On/Off switch in the Off position before inspecting or servicing any part of the unit.*



Battery Installation and Cable Routing



WARNING: Improperly installed battery could result in a fire or explosion. A Thermo King approved battery must be installed and properly secured to the battery tray.



WARNING: Improperly installed battery cables could result in fire or explosion. Battery cables must be installed, routed and secured properly to prevent them from rubbing, chaffing or making contact with hot, sharp or rotating components.



CAUTION: Do not connect other manufacturer's equipment or accessories to the Thermo King unit. This could result in severe damage to equipment and void the warranty.



CAUTION: Set all unit electrical controls to the OFF position before connecting battery cables to the battery to prevent unit from starting unexpectedly and causing personal injury.



CAUTION: Always wear protective clothing, gloves and eye wear when handling and installing batteries. Battery acid can cause serious burns when exposed to eyes or skin. If battery acid contacts skin or clothing, wash immediately with soap and water. If acid enters your eye, immediately flood it with running cold water for at least twenty minutes and get medical attention immediately.



CAUTION: Always cover battery terminals to prevent them from making contact with metal components during battery installation. Battery terminals grounding against metal could cause the battery to explode.

Refrigerant

Although fluorocarbon refrigerants are classified as safe, use caution when working with refrigerants or in areas where they are being used.

NOTE: These warnings refer to servicing of the unit.



DANGER: Fluorocarbon refrigerants can produce toxic gases. In the presence of an open flame or electrical short, these gases are severe respiratory irritants **CAPABLE OF CAUSING DEATH.**



DANGER: Fluorocarbon refrigerants tend to displace air and can cause oxygen depletion which could result in **DEATH BY SUFFOCATION.** Provide adequate ventilation in enclosed or confined areas.



WARNING: Fluorocarbon refrigerants evaporate rapidly, freezing anything they contact if accidentally released into the atmosphere from the liquid state.

Refrigerant Oil

Observe the following precautions when working with or around refrigerant oil:

NOTE: These warnings refer to servicing of the unit.



WARNING: Always wear goggles or safety glasses to protect eyes from refrigerant oil contact.



WARNING: Protect skin and clothing from prolonged or repeated contact with refrigerant oil. Rubber gloves are recommended.



WARNING: Wash thoroughly immediately after handling refrigerant oil to prevent irritation.

First Aid

First Aid–Refrigerant

Eyes: For contact with liquid, immediately flush eyes with large amounts of water. Get prompt medical attention.

Skin: Flush areas with large amounts of warm water. Do not apply heat. Wrap burns with dry, sterile, bulky dressing to protect from infection or injury. Get prompt medical attention.

Inhalation: Move victim to fresh air and restore breathing if necessary. Stay with victim until emergency personnel arrive.

First Aid–Refrigerant Oil

Eyes: Immediately flush eyes with large amounts of water for at least 15 minutes while holding the eyelids open. Get prompt medical attention.

Skin: Remove contaminated clothing. Wash thoroughly with soap and water. Get medical attention if irritation persists.

Inhalation: Move victim to fresh air and restore breathing if necessary. Stay with victim until emergency personnel arrive.

Ingestion: Do not induce vomiting. Immediately contact local poison control center or physician.

Safety Decals and Locations

Service

The Service decal is located inside the Control Box Door. This decal gives you the information to access/download your unit operator manual, but also the safety icons associated with your unit. These safety icons are directly associated with the information within this chapter. You can see the explanations for these icons starting from “General Safety Practices” on page 6. See “Service Decal” on page 10

NOTE: *This decal only contains symbols of warning for the service of the unit.*



Figure 1: Service Decal

Operation

The Operation decal is located in an appropriate position near your in-cab controller or rear remote controller (if fitted). This decal gives you the information to access/download your unit operator manual



Figure 2: Operation Decal

Condenser and Evaporator Fans

Locations vary depending on model. Decals are located near areas that contain fans which can cause severe injuries if hands or clothing become tangled.



BEN217

Figure 3: Fan Warning

Refrigerant

Refrigerant decal located on unit frame.



BEN501

F Gas decal indicates that this equipment Contains fluorinated greenhouse gases.

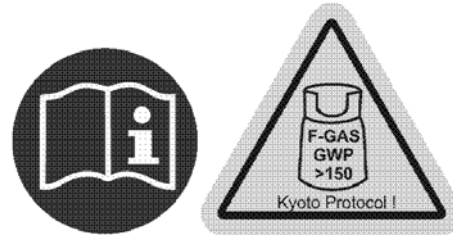

Do Not Use Ether Starting Aids

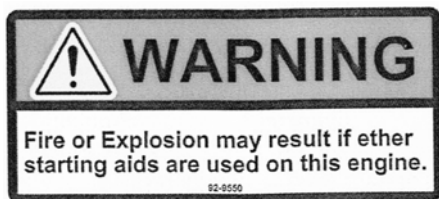

**Figure 4: Do Not Use Ether Starting Aids
(Near Engine)**

Unit Description

General Information

The UT-Series unit is a microprocessor based transport temperature control system that uses the TSR-3 Truck HMI microcontroller to manage system functions.

The unit is under-mounted, diesel powered cooling and heating system designed for straight trucks. It is designed for use with chlorine free R-404A/R-452A refrigerant. Remote evaporators are used to control temperatures in up to three individual cargo compartments. The basic models provide the following:

Cooling and hot gas heating on engine operation and electric standby operation.



Figure 5: Front View

Diesel Engine

Engine power for the UT-Series unit is provided by the TK376, a three cylinder, clean and quiet diesel engine. The UT-1200 and UT SPECTRUM are rated at 19.6 continuous horsepower (14.6 kW) at 2425 RPM whereas the UT-800 is rated at 19.0 horsepower (14.2 kW) at 2200 RPM. A belt drive system transfers energy to the compressor, unit fans and alternator.

ELC (Extended Life Coolant)

ELC (Extended Life Coolant) is standard equipment. The maintenance interval for ELC is five years or 12,000 hours. A nameplate on the coolant expansion tank identifies units with ELC. The new engine coolant, Chevron Extended Life Coolant, is RED in color instead of the previous GREEN or BLUE-GREEN colored conventional coolants.



CAUTION: Do not add "GREEN" or "BLUE-GREEN" conventional coolant to cooling systems using "RED" Extended Life Coolant, except in an emergency. If conventional coolant is added to Extended Life Coolant, the coolant must be changed after 2 years instead of 5 years.

NOTE: The use of 50/50% pre-mixed ELC is recommended to assure that de-ionized water is being used. If 100% full strength concentrate is used, de-ionized or distilled water is recommended instead of tap water to insure the integrity of the cooling system is maintained.

Clutch

The centrifugal clutch engages fully at 600 ± 100 RPM on engine operation, constantly turning the compressor, alternator, and fans at both high and low speed. The clutch isolates the engine from the belt drive system during electric standby operation.

Thermo King Scroll Compressor

The UT-1200, UT SPECTRUM and UT-800 feature the reliable TKO Scroll 6.0 hp compressor..

HMI Control Panel

Standard

The Standard HMI Control Panel (Human/Machine Interface) is used to operate the unit and display unit information. The Control Panel is typically located in the vehicle driver's compartment and communicates with the base controller using a connection on the interface board.



Figure 6: Standard HMI Control Panel

Premium

The Premium Truck HMI (Human/Machine Interface) Control Panel is available as an option on TSR-3 applications. It is used to operate the unit, display unit information and access all

TSR-3 Maintenance and Guarded Access Menus. The Control Panel is typically located in the vehicle driver's compartment and communicates with the base controller using a connection on the interface board.

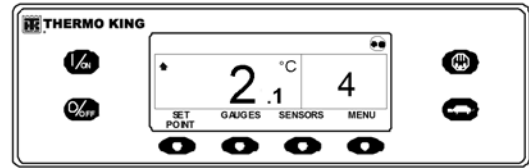

Figure 7: Premium HMI Control Panel

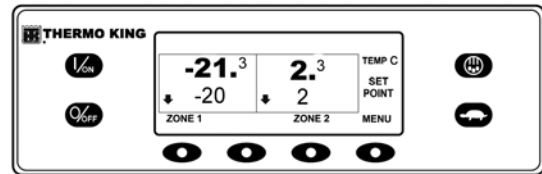

Figure 8: Premium HMI Control Panel - Spectrum

CYCLE-SENTRY™ Start-Stop Controls

The CYCLE-SENTRY Start-Stop fuel saving system provides optimum operating economy. When CYCLE-SENTRY Mode is selected the unit will start and stop automatically to maintain setpoint, keep the engine warm and the battery charged. When Continuous Mode is selected, the unit starts automatically and runs continuously to maintain setpoint and provide constant airflow.

Defrost

Frost will gradually build up on the evaporator coils as a result of normal operation. Periodically this frost must be melted to prevent a loss of cooling and airflow.

Defrost is accomplished by passing hot refrigerant gas through the evaporator coil, thus melting the frost (or ice). Melted frost drains out of the unit onto the ground through the drain tubes. The defrost damper closes during defrost to prevent warm air from entering the cargo area. The optional electric heater strips are also energized in defrost during electric standby operation.

Defrost can be initiated at any time the evaporator coil temperature is below 42 F (5.5 C).

There are two methods of defrost initiation:

TSR/TSR-3 Microprocessor Controller

The Microprocessor Controller is programmed to automatically initiate timed and forced defrost cycles. The TSR/TSR-3 uses temperature sensors to determine if forced defrost is required.

Manual Defrost

Manual Defrost allows the operator to initiate a defrost cycle by pressing the Defrost key. See “Initiating a Manual Defrost Cycle.”

DAS - Data Acquisition System

NOTE: (Optional)

The DAS (Data Acquisition System) monitors and records the temperatures of (up to) six additional sensors. The sensors are independent from the microprocessor controller and are

Unit Description

normally located in the truck box to monitor load temperatures. DAS data can be downloaded through a serial port to an IBM® PC compatible computer. WinTrac™ 4.8 (or higher) software is used to view and analyze the data. Brief reports can be printed on a microprinter connected to the serial port.

Electric Standby

The Electric Standby option allows the unit to be operated on either the diesel engine or external electric power. During Electric Standby operation, power to the unit is supplied by an electric motor connected to a high voltage power source. Check the unit for proper power source ratings.

Electric Power Receptacle

The electric power receptacle is used to connect the unit to an appropriate electric power source for electric standby operation. Turn the unit OFF before connecting or disconnecting the power cord.

Standard Features

The following features are standard equipment on units equipped with Electric Standby.

Automatic Diesel/Electric Selection

The unit will automatically switch to electric operation when a power cord is connected and the standby power is switched On.

Overload Relay

The overload relay is self-resetting.

Hot Gas Heat

Hot gas heat is utilized on all units.

Automatic Phase Correction

The control system features two motor contactors. This allows correct motor rotation regardless of phase rotation on the incoming power.

Unit Description

Optional Features

The following features are available as an option on units equipped with Electric Standby.

- Autoswitching

Engine Compartment Components

Coolant Expansion Tank

The coolant level and temperature are monitored by the base controller. If the coolant temperature becomes too high or the level becomes too low, an alarm will occur.

The engine must have antifreeze protection to -34 C (-30 F). Check and add coolant in the expansion tank as needed.



WARNING: *The unit can start at any time without warning. Press the OFF key on the control panel and place the microprocessor On/Off switch in the Off position before inspecting any part of the unit.*

Engine Oil Dipstick

Use the engine oil dipstick to check the engine oil level.



CAUTION: *Make sure the engine is turned off before attempting to check the engine oil.*

Receiver Tank Sight Glass

The receiver tank sight glass is used to assist in checking the amount of refrigerant in the system.

Compressor Oil Sight Glass

The compressor oil sight glass is used to check the relative level of compressor oil in the compressor sump.

Unit Protection Devices

High Pressure Cutout Switch (HPCO): This normally closed switch monitors the discharge pressure at the compressor. It opens on high discharge pressure to shut the unit down to prevent damage.

Unit Description

Engine Oil Pressure Switch/Sensor: The engine oil pressure switch/sensor is located on the filter head above the bypass oil filter. Engine oil pressure should rise immediately on starting. If engine oil pressure drops below 10 ± 2 psig (69 ± 14 kPa), the switch/sensor signals the microprocessor to stop the engine.

Preheat Buzzer: The preheat buzzer sounds when the CYCLE-SENTRY™ system energizes the glow plugs. This should warn anyone near the unit that the CYCLE-SENTRY™ system is about to start the diesel engine.

Coolant Temperature Sensor: This sensor provides an engine coolant temperature input to the microprocessor. If the engine coolant temperature is too high, the controller stops the unit and records an alarm.

Electric Motor Overload Relay: The overload relay protects the electric standby motor. The overload relay opens the circuit from the contactor to the electric motor if the motor overloads for any reason and an alarm will occur. The relay resets when the alarm code is cleared.

Fuses: Sizes and functions are described in the Specifications section of this manual.

Unit Description

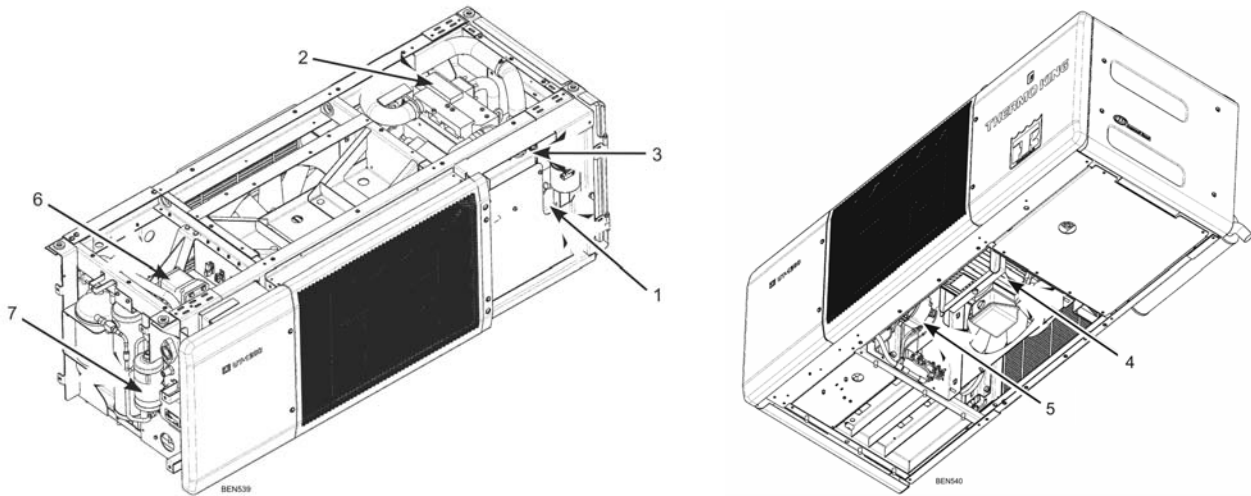

1.	Engine Oil Dipstick (on side of engine)	5.	Alternator
2.	Engine	6.	Compressor
3.	Coolant Expansion Tank	7.	Dehydrator (Filter-Drier)
4.	Electric Motor		

Figure 9: Main Components in UT-Series Units

Unit Description

Pharma

Single temperature units qualified for pharmaceutical applications under Thermo King protocol. Please follow the following recommendations:

- To maintain the best temperature management within the load-space it is recommended to operate with the following set-point temperatures in the following ranges.
 - +20 °C Set-Point for temperature range +15 °C to +25 °C
 - +5 °C Set-Point for temperature range +2 °C to +8 °C
 - -25 °C Set-Point for temperature below -20 °C
- For optimum temperature management and air distribution, the refrigeration unit's continuous operation mode must be used for all temperature ranges.
- Efficient loading practices and operating procedures have to be followed to ensure optimum air circulation and temperature management.

Manual Pretrip Inspection

Before Starting the Unit

Pretrip inspections are an important part of a preventative maintenance program designed to minimize operating problems and breakdowns. Perform this pretrip inspection before every trip involving refrigerated cargo.

NOTE: Please refer to “Pre-Loading Inspection” on page 36 also before commencing your journey.

NOTE: Pretrip inspections are not intended to take the place of regular maintenance inspections.

Fuel: Make sure the diesel fuel supply is adequate to guarantee engine operation to the next check point. Allow for maximum fuel consumption of 3.8 Litres (one gallon) per hour of engine operation.

Engine Oil: Check the engine oil level. It should be at the Full mark when the dipstick is threaded all the way into the oil pan. Do not overfill.



CAUTION: Turn the engine off before checking the engine oil level.

Engine Coolant: Check the coolant level in the overflow bottle. It should be above the Full Cold line. If necessary, add coolant to the overflow bottle. The engine coolant should be a 60/40 mixture and must have antifreeze protection to -34 C (-30 F). Add coolant if Alarm Code 37 is active. Check and add coolant to the expansion tank.

NOTE: Please see Specifications chapter and “Engine” on page 37 where it is clearly states which coolant types are allowed to be used in this unit.



WARNING: Do not remove the expansion tank cap while the coolant is hot.

Battery: Make sure the battery terminals are tight and free of corrosion.

NOTE: All truck and trailer units will have a small battery drain when the unit is off. The battery can be drained even quicker if there are Aftermarket options or third party devices connected to the unit which consume battery power.

This will cause the battery to become discharged over time.

Apart from the obvious inconvenience of having to charge the battery, it is also liable to damage battery cell material and cause the life of the battery to be shorter than acceptable.

Therefore, to ensure the battery remains in optimum condition during periods when the unit is not being used, Thermo King strongly recommends to switch on the unit at least once each week and run for 30 minutes or longer.

Failure to do so may result in warranty for the battery being rejected.

Alternatively, Thermo King offer a solar panel option from aftermarket which would negate the requirement to switch off the microprocessor switch during long unit idle periods. For more information, please contact your local Thermo King dealership.

Belts: Make sure belts are in good condition and adjusted to the proper tension. For more information about belt tension, see the Specifications chapter.

Electrical: Check the electrical connections to make sure they are securely fastened. Wires and terminals should be free of corrosion, cracks, and moisture.

Structural: Visually inspect the unit for leaks, loose or broken parts, and other damage.

Coils: Ensure condenser and evaporator coils are clean and free of debris.

- Washing with clean water should be sufficient.
- The use of cleaning agents or detergents is strongly discouraged due to the possibility of degradation of the construction.
- If using a power washer, the nozzle pressure should not exceed 600 psi (41 bar). For the best results, spray the coil perpendicular to the face of the coil. The spray nozzle should be kept between 1 inch and 3 inches (25 to 75 millimeters) from the coil surface.

Manual Pretrip Inspection

- If necessary to use a chemical cleaner or detergent use a cleaner that does not contain any hydrofluoric acids and is between 7 and 8 on the pH scale. Ensure dilution instructions provided by the detergent supplier are followed. In case of doubt about the compatibility of the detergent with the type of materials listed above, always ask the supplier a written confirmation of the compatibility.
- Should a chemical cleaner be required, it is MANDATORY that all components are thoroughly rinsed with water even if the instructions of the cleaner specify that it is a “no rinse” cleaner.

WARNING: *Failure to comply with above mentioned guidelines will lead to a shortened life of the equipment to an indeterminable degree and also may void your warranty.*

NOTE: *The repeated transportation of meat and fish waste can cause extensive corrosion to the evaporator coils and evaporator section tubing over time due to ammonia formation and can reduce the lifespan of the coils.*

Appropriate additional measures should be taken to protect the coils against the aggressive corrosion that can result from transportation of such products.

Cargo Box: Check the interior and exterior of the cargo box for damage. Any damage to the walls or insulation must be repaired.

Cargo Doors: Make sure that the cargo doors and weather seals are in good condition. The doors should latch securely and the weather seals should fit tightly.

Defrost Drains: Check the defrost drain hoses to make sure they are open.

Remote Evaporators : UT SPECTRUM

- Visually inspect Evaporator(s) for damaged, loose, or broken parts.
- Check also for refrigerant leaks.
- Check Defrost initiation and termination (including defrost timer) by activating/initiating a manual defrost.

Operating Instructions

Unit Operating Instructions Premium HMI Controller

The Premium Truck HMI (Human/Machine Interface) Control Panel is available as an option on TSR-3 Truck applications. It is used to operate the unit, display unit information and access all TSR-3 Maintenance and Guarded Access Menus. The Premium HMI Control Panel communicates with the base controller via the CAN (Controller Area Network) bus. It is connected to the base controller via CAN Connector J14 on the interface board. The Premium HMI Control Panel is typically located in the vehicle driver's compartment. It may be installed in the truck instrument panel using a DIN mounting ring or under the instrument panel using an under dash mounting kit.

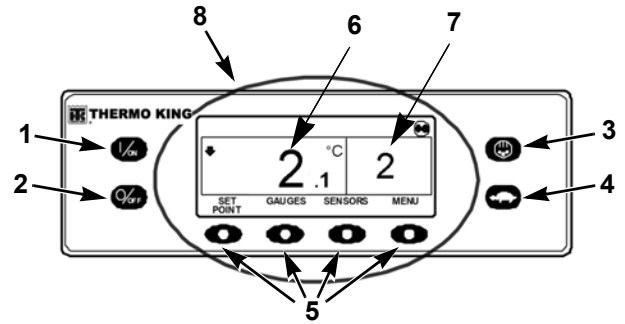

Premium HMI Control Panel Display

	Hard Keys
1.	On Key
2.	Off Key
3.	Defrost
4.	High Speed Lockout

Operating Instructions

5.	Soft Keys
6.	Box Temperature
7.	Setpoint
8.	Display

Figure 10: Premium HMI Control Panel Display

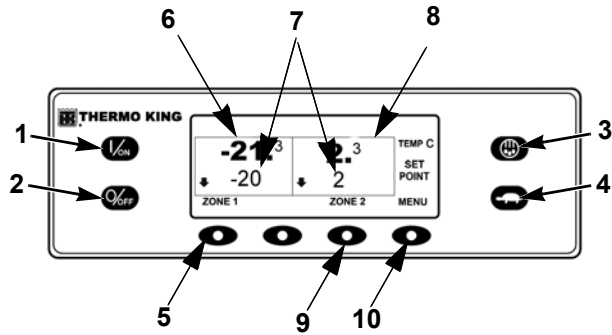

	Hard Keys
1.	On Key
2.	Off Key
3.	Defrost
4.	High Speed Lockout
5.	Zone 1 Soft Keys
6.	Box Temperature
7.	Setpoints
8.	Zone 2 Display
9.	Zone 2 Soft Key
10.	Menu Soft Key

Figure 11: SPECTRUM - Premium HMI Control Panel Display

The HMI control panel consists of a display and 8 touch-sensitive keys. The display is capable of showing both text and graphics.

Operating Instructions

The keys on the left and right sides of the display are dedicated single function "hard" keys.

The four keys under the display are "soft" keys. The functions of these soft keys change depending on the operation being performed. If a soft key is active the current key function is shown in the display directly above the key.

Controller Features

- Displays Box Temperature and Setpoint in Fahrenheit or Celsius
- Displays Engine Running and Motor Running Hourmeters
- Changes Setpoint
- Indicates Alarm Condition Exists
- Displays and Clears Alarms
- Selects and Indicates CYCLE-SENTRY or Continuous Mode Operation
- Selects and Indicates High Speed Lock-Out Operation
- Initiates and Indicates a Defrost Cycle
- Initiates and Indicates a Pretrip Test

- Sends a Start of Trip to the ServiceWatch data logger.

Display

The display presents information to the operator. This information includes setpoint and temperature, unit operating information, gauge readings, temperatures and other information as selected by the operator.

The Standard Display of box temperature and setpoint is shown here. The CYCLE-SENTRY Icon in the upper right of the display shows the unit is running in CYCLE-SENTRY (Start-Stop) Mode. The unit has a setpoint of 2 C, and an actual box temperature of 2.1 C. The down-pointing arrow at the left side of the display shows the unit is cooling.

The four keys under the display are termed "soft" keys. The functions of these keys change depending on the operation being performed. The function of each soft key is shown by labels in the display located directly above each soft key. In the example shown above, pressing the left soft key accesses the SETPOINT and pressing the right soft key accesses the MAIN MENU. The other two soft keys access the GAUGES menu and SENSORS menu as shown by the labels above the keys.

Keys

Hard Keys

The keys on either side of the display are dedicated or "hard" keys. Their function always remains the same.

Soft Keys

Soft Key Description

The four "soft" keys under the display are multi-purpose keys. Their function changes depending on the operation being performed. If a soft key is active the key function is shown in the display directly above the key. The keys are numbered from left to right, with Key 1 on the far left and Key 4 on the far right.

Typical soft key functions:

MENU

NEXT/BACK

YES/NO

+/-

SELECT/EXIT

CLEAR/HELP

HOUR METERS/SENSORS

GAUGES

Operating the TSR-3 Controller

Please refer to Profeesor Kool and the "TK Tutor Series" for step by step instructions and training on how to use your Standard or Premium HMI and also "TK Alarm Codes" to help diagnose any alarms. These can be found at the following link: <http://www.europe.thermoking.com/tools/>

NOTE: These are App's are developed for your Mobile device, please contact your Dealer for desktop applications.

Alarm Codes

Introduction

An alarm code is generated when the microprocessor senses an abnormal condition. Alarms direct an operator or service technician to the source of a problem.

Multiple alarms can be present at one time. All generated alarms will be stored in memory until cleared by the operator. Document all alarm occurrences and report them to the service technician.

NOTE: Please refer to *Profesor Kool and the “TK Tutor Series” App* for step by step instructions and training on Alarm types and how to clear alarms. Please refer to “TK Alarm Codes” App for the most up to date alarms list. These app’s can be found at the following link:

www.europe.thermoking.com/tools/

NOTE: The alarm codes leaflet can also be downloaded from this site, or from the EMEA user manuals website at www.emea-user-manuals.thermoking.com/

NOTE: Some alarms (3, 4, 74, 203, and 204) cannot be cleared in the Alarms Menu, they must be cleared in the Maintenance Menu or the Guarded Access Menu. Contact your supervisor or a Thermo King dealer about clearing those alarms.

IMPORTANT: Always record any Alarm Codes that occur - in the order that they occur - as well as any other pertinent information. This information is extremely valuable to service personnel.

NOTE: In some cases alarms cannot be cleared, or cannot be cleared after they have occurred a specified number of times. If such is the case, these alarms must be cleared by service personnel. These are all explained in your Alarm Codes App.

Loading and Enroute Inspections

This chapter describes pre-loading, post loading, and enroute inspection procedures. Thermo King refrigeration units are designed to maintain the required product load temperature during transit. Follow these recommended loading and enroute procedures to help minimize temperature related problems.

Pre-Loading Inspection

1. Check the engine oil pressure indicates OK. When first starting a cold engine, the oil pressure may be higher.
2. Pre-cool products before loading. Note any variances on the manifest.
3. Inspect door seals and vent doors for condition and a tight seal with no air leakage.
4. Inspect the truck inside and out. Look for:
 - Damaged or loose truck skin and insulation
 - Damaged walls, air ducts, floor channels or “T” flooring

- Clogged defrost drain tubes
- Blocked return air bulkhead

5. Verify that the setpoint temperature is correct for your cargo. Pre-cool the truck as required.
6. Supervise product loading to ensure sufficient air space around and through the load. Airflow around the cargo must not be restricted.

NOTE: If the warehouse is not refrigerated, operate the unit with doors closed until cargo is ready to be loaded. Then turn off the unit, open cargo doors and load cargo. When cargo is loaded, close truck doors and restart the unit.

The unit can be operated with the cargo box doors open if the truck is backed into a refrigerated warehouse and the dock door seals fit tightly around the truck.

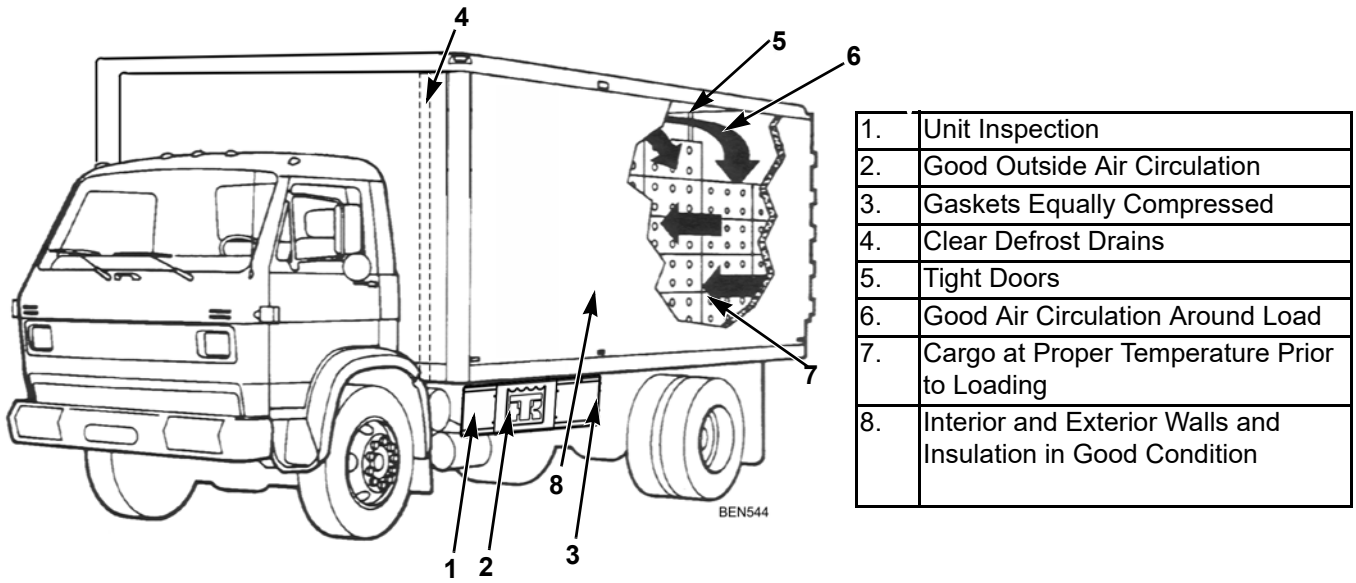

Figure 12: Loading Considerations

Post-Loading Inspection

Post-loading inspections ensure the cargo has been loaded properly. To perform a post-load inspection:

1. Inspect the evaporator outlets for blockage.
2. Turn the unit off before opening the cargo box doors to maintain efficient operation.

NOTE: The unit can be operated with the cargo box doors open if the truck is backed into a refrigerated warehouse and the dock door seals fit tightly around the truck.

3. Perform a final check of the load temperature. If the load is above or below temperature, make a final notation on the manifest.



CAUTION: Cargo must be pre-cooled to the proper temperature before loading. The unit is designed to maintain temperature, not cool an above-temperature load.

4. Close or supervise the closing of the cargo box doors. Make sure they are securely locked.
5. Make sure the setpoint is at the temperature listed on the manifest.
6. If the unit was stopped, restart using the correct starting procedure. See the Operating Instruction chapter in this manual.
7. Start a manual defrost cycle 30 minutes after loading. See the Manual Defrost procedure in this manual.

Enroute Inspections

Complete the following enroute inspection every four hours. This will help minimize temperature related problems.

Inspection Procedure

1. Verify setpoint is correct.
2. Check the return air temperature reading. It should be within the desired temperature range.
3. Initiate a manual defrost cycle after each enroute inspection.

Inspection Troubleshooting

1. If a temperature reading is not within the desired temperature range, refer to the troubleshooting table on the following pages. Correct problem as required.

2. Repeat the Enroute Inspection every 30 minutes until the compartment temperature is within the desired temperature range. Stop the unit if the compartment temperature is not within the desired temperature range on two consecutive 30 minute inspections, especially if the compartment temperature appears to be moving away from the setpoint.
3. Immediately contact the nearest Thermo King Dealer or your company office.
4. Take all necessary steps to protect and maintain proper load temperature.

Loading and Enroute Inspections



CAUTION: Stop the unit if the compartment temperature remains higher than the desired temperature range from the setpoint on two consecutive 30 minute inspections. Contact the nearest Thermo King Dealer or your company office immediately. Take all necessary steps to protect and maintain proper load temperature.

Inspection Troubleshooting

Problem	Cause	Remedy
A return air temperature reading is not within desired temperature range of the setpoint.	The unit has not had time to cool down to correct temperature.	Refer to the load log history. Look for above temperature load records, properly pre-cooled cargo compartment, length of time on road, etc. Correct as required. Continue monitoring return air temperature until the reading is within the desired temperature range of the setpoint. <i>NOTE: Ensure cargo is properly pre-cooled prior to loading onto truck. If 'warm cargo' is loaded onto truck and reefer is used to cool to setpoint this will result in longer time required to cool down to correct temperature and possibly plugging of evaporator with frost due to increased humidity in truck compartment.</i>
	The unit may have a low refrigerant charge.	Check the receiver tank sight glass for refrigerant level. If liquid is not showing in the receiver tank sight glass, the refrigerant charge may be low. A competent refrigeration technician is required to add refrigerant or repair the system. Contact the nearest Thermo King dealer.
	The unit is in defrost or has just completed a defrost cycle.	Monitor the return air temperature after the defrost cycle is completed to see if the temperature returns to the desired temperature range of the setpoint.
	The evaporator is plugged with frost.	Initiate a manual defrost cycle. The defrost cycle will automatically terminate when complete. Continue monitoring the return air temperature until the reading is within the desired temperature range of the setpoint.

Inspection Troubleshooting

Problem	Cause	Remedy
	Improper air circulation in the cargo compartment.	Inspect the unit and cargo compartment to determine if the evaporator fan(s) are working and properly circulating the air. Poor air circulation may be due to improper loading of the cargo, shifting of the load, or fan belt slippage. Correct as required. Continue monitoring return air temperature until problem is corrected.
	The unit did not start automatically.	Determine the cause for not starting. Correct as required. Continue monitoring the return air temperature until the reading is within the desired temperature range of the setpoint.

Specifications

Engine

Model:	UT-1200, UT SPECTRUM, UT-800, UT Extreme ^{HIGH} Ambient	Thermo King TK 376U
Fuel Type		Diesel Fuel must conform to EN 590
Oil Capacity		Crankcase and Oil Filter: 11.0 litres, w/ Bypass Oil Filter: 12.1 litres. Fill to full mark on dipstick
Oil Type		Petroleum Multi-grade Oil: API Type CI-4, ACEA Class E3 Synthetic Multi-grade Oil (after first oil change): API Type CI-4, ACEA Class E3

Engine (Continued)

<p>Recommended oil viscosity based on ambient temperature</p>	<p>-10 C to 50 C (14 F to 122 F): SAE 15W-40 (Synthetic) -15 to 40 C (5 to 104 F): SAE 15W-40 -15 to 40 C (5 to 104 F): SAE 10W-30 (Synthetic or Synthetic Blend) -25 to 40 C (-13 to 104 F): SAE 10W-40 -25 to 30 C (-13 to 86 F): SAE 10W-30 -30 to 50 C (-22 to 122 F): SAE 5W-40 (Synthetic) Below -30 C (-22 F): SAE 0W-30 (Synthetic)</p>
<p>Engine RPM: UT-1200, UT SPECTRUM, UT Extreme ^{HIGH} Ambient UT-800</p>	<p>High Speed 2425 ± 25 RPM Low Speed 1625 ± 25 RPM 2250 ± 25 rpm High Speed 2200 ± 25 RPM Low Speed 1450 ± 25 RPM</p>

Engine (Continued)

Engine Coolant Type	<p>Conventional Coolant: Conventional coolant (antifreeze) is green or blue-green. GM 6038M or equivalent, low silicate antifreeze mixture, 50/50 antifreeze/water mixture, not to exceed 60/40.</p> <p>CAUTION: Do not mix conventional coolant and ELC. ELC (Extended Life Coolant): ELC is red. Units containing ELC have an ELC nameplate on the expansion tank. Use a 50/50 concentration of any of the following equivalents: Texaco ELC (7997, 7998, 16445, 16447), Havoline Dex-Cool® (7994, 7995), Havoline XLC for Europe (30379, 33013), Shell Dexcool® (94040), Shell Rotella (94041), Saturn/General Motors Dex-Cool®, Caterpillar ELC, Detroit Diesel POWERCOOL® Plus</p>
CAUTION: Do not use high silicate automobile antifreeze	
Coolant System Capacity	Check the coolant level in the overflow bottle. It should be above the Full Cold line. If necessary, add coolant to the overflow bottle.
Coolant Expansion Tank Cap Pressure UT-Series	7 psig (48 kPa)

Fuses

Fuse	Size	Function
F2	15A	Power to On/Off Switch
F3	40A	Fuel Sol Pull-In/Starter Circuit
F4	None 2A	No Fuse - All Bosch and Thermo King Alternators 2A Fuse - All Prestolite Alternators
F5	40A	Preheat Circuit
F6	15A	High Speed Circuits
F7	2A	8XP Circuit - Controller On Feedback to HMI
F8	5A	2A Power to CAN Connector J12
F9	5A	2A Power to CAN Connector J14
F10	10A	8X Power (Install fuse in upper position)
F11	10A	Zone 1 LLS
F12	5A	CAN Connector J13

Fuse	Size	Function
F13	2A	8FC Circuit (Remote Lights)
F20	2A	Alternator Sense
F21	60A	Main Fuse (2 Circuit)
F25	7.5A	HPCO/Run Circuit
F4 Depending on your unit, this fuse maybe removed, please consult your Dealer for further information.		
F10 When fuse F10 is installed in the upper position the On/Off keys on the HMI turn the unit on and off. When fuse F10 is installed in the lower position the unit will start and run without the HMI control panel.		

Specifications

Electrical Control System

Low Voltage	12.5 Vdc (nominal)
Voltage Regulator Setting	13.8 to 14.4 volts @ 77 F (25 C).
Battery	12 Volt, AHr Rating - 75 AHrs, 640 Cold Cranking Amps at -18C (ENCCA)
Battery Charging	120 amp, (Brush Type) Integral Alternator used with UT-1200, UT SPECTRUM. 65 amp, (Brush Type) Integral Alternator used with UT-800

Standby Power Requirements

Supply Circuit Breaker:	
200-230/3/50-60 (UT-Series unit)	50 amps
All 380-46/3/50-60 (UT-Series unit)	20 amps
Extension Cord Size:	Up to 15 m — 10 gauge 23 m — 8 gauge

Refrigeration System

Contact your Thermo King dealer for refrigeration system service or maintenance.

Warranty

Terms of the Thermo King Self Powered Truck Unit Warranty are available on request from your Thermo King Dealer.

Please also refer to TK 61598-2-WA Thermo King EMEA Limited Warranty for Self Powered Truck Units.

Maintenance Inspection Schedule

Inspection and Service intervals

Inspection and Service intervals are determined by the number of unit operating hours and by the age of the unit. Examples are shown in the table below. Your Dealer will prepare a schedule to suit your specific needs.

Interim Inspection	Complete PM
A Service Every 1000 hours or every 6 months (whichever comes first)	B Service Every 2000 hours or every 24 months (whichever comes first)

Pretrip	Inspect/Service These Items
	<ul style="list-style-type: none"> • Run Pretrip Test (See "Operating the TSR-3 Controller" on page 28) • Check fuel supply. • Check and adjust coolant/engine oil levels. • Listen for unusual noises, vibrations, etc. • Visually inspect unit for fluid leaks. (fuel, coolant, oil and refrigerant). • Visually inspect unit for damaged, loose or broken parts (includes air ducts and bulkheads if so equipped).

NOTE: For further best practices, please go to www.europe.thermoking.com/best-practices

Maintenance Inspection Schedule

Service Record

Each inspection and service performed should be recorded on your Dealer Service Record. This may be provided by you Thermo King Dealer Representative, or you can download one from the [EMEA User Manuals Website](#).

Serial Number Locations

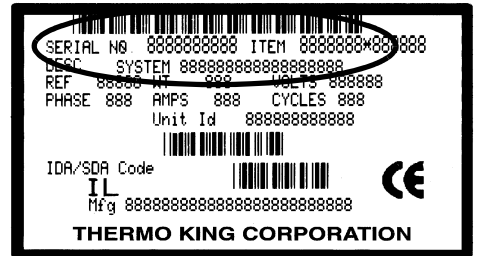
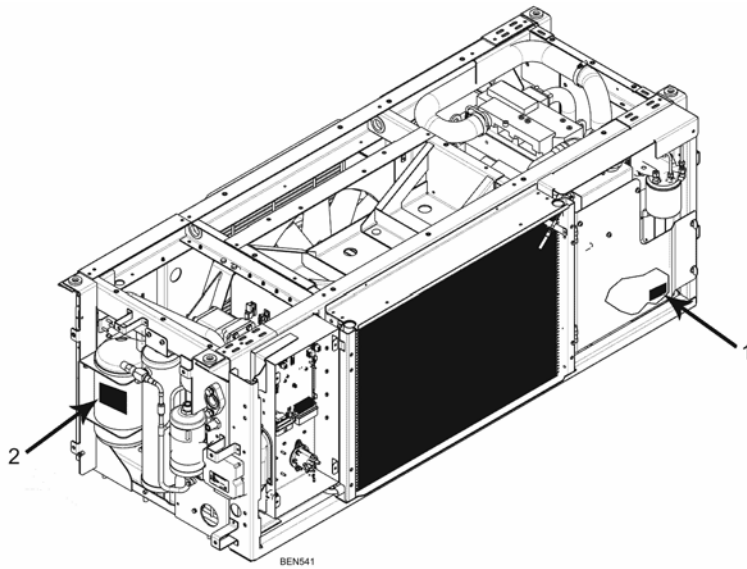

Serial Number Plate and Location

Recover Refrigerant

At Thermo King, we recognize the need to preserve the environment and limit the potential harm to the ozone layer that can result from allowing refrigerant to escape into the atmosphere.

We strictly adhere to a policy that promotes the recovery and limits the loss of refrigerant into the atmosphere.

In addition, service personnel must be aware of Federal regulations concerning the use of refrigerants and the certification of technicians. For additional information on regulations and technician certification programs, contact your local THERMO KING dealer.